

ProAct™ III and IV Actuators

All-electric Actuator Systems for Fuel Control of Larger Engines

Applications

The ProAct actuators provide 75° of actuator output rotation to move an attached lever and linkage which sets engine fuel or engine rack settings.

The ProAct III and IV actuators are available for either clockwise or counterclockwise rotation of the output shaft toward maximum fuel. Output rotation toward maximum fuel must be determined at the time equipment is ordered.

The ProAct III or IV driver requires a separate electrical supply of 20–32 Vdc. The supply must be capable of supplying a sustained 10 A and a peak 20 A current for up to 2 seconds.

The actuator provides the muscle for Woodward analog controls such as the 2301A, as well as Woodward digital controls. ProAct III or IV actuators must be linked with an electronic driver, separate from the actuator, located between the electronic control and the actuator. The actuator is designed for direct installation on the engine.

Description

The ProAct™ III and IV actuator are for actuation of larger diesel, gas, and gasoline engines. These systems are well suited for engines without a mechanical drive or hydraulic-oil supply.

The driver has adjustments which match the actuator to the output from the particular control.

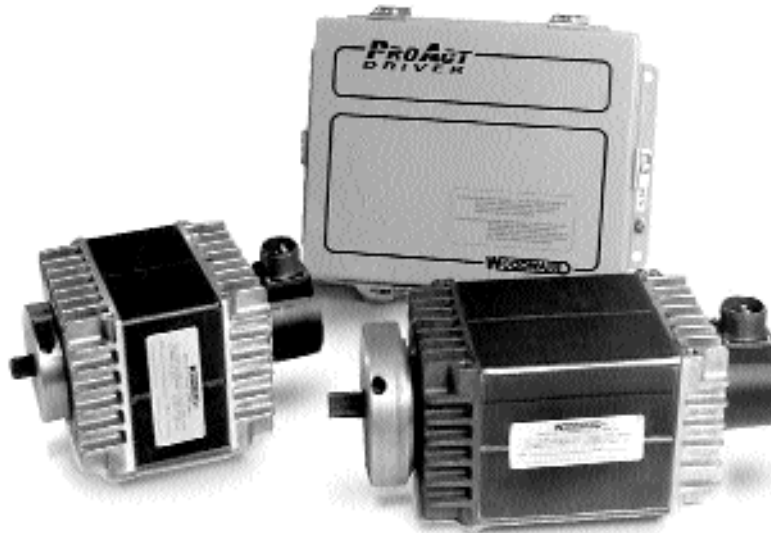

- 5 and 10 lb-ft/7 and 14 N·m (10 and 20 lb-ft/14 and 27 N·m during fuel system transients) 75° actuators for control of engine
- CW or CCW to maximum fuel
- All-electric system eliminates need for governor/actuator drives
- Drivers available for 20–160 or 4–20 mA electronic controls
- Position feedback for extreme speed and stiffness, precise output location and position readout

Specifications

Driver Box

Ambient Temperature Range
Installation

-40 to +70 °C (-40 to +158 °F)

The driver box is designed for installation on the control panel and should not be installed directly on the engine. Ideally, the driver should be mounted flush to the metal side of a control cabinet, and close to the engine being controlled.

Input Voltage

24 Vdc nominal, 20 to 32 Vdc limits. 24 Vdc or higher will give better performance, especially if longer wire lengths are required for the installation. Voltages below 24 Vdc will result in reduced work output available from the actuator.

Input/Output

With 20–200 mA controls, 20 mA input produces about 2.5 degrees of actuator travel. 160 mA can produce an additional 70 degrees of actuator travel. With 4–20 mA controls, 4 mA input produces about 2.5 degrees of actuator travel. 12 mA can produce an additional 70 degrees of actuator travel. The actual range and position is set with offset and span adjustments on the driver.

Actuator

Output Shaft

ProAct III .625-36 (inch) serration on output shaft
ProAct IV .750-48 (inch) serration on output shaft

Operating Temperature Range

-40 to +100 °C (-40 to +212 °F) operating environment. The actuator operates equally well at -40 or 100 °C.

Construction

All external surfaces are resistant to water and salt water corrosion. Actuator is waterproof at normal water-hose pressure. Do not high-pressure wash.

Feedback

Contactless Hall effect feedback device directly connected to actuator shaft

Installation

Installed with four 0.312-18 (inch) bolts into the base. The actuator may be mounted in any configuration. Output may be linked to rack or valve.

Vibration and Shock Tested

Tested to US MIL-STD-810C

Vibration: 5–2000 Hz @ 10 G acceleration

Shock: 100 G for 6 ms

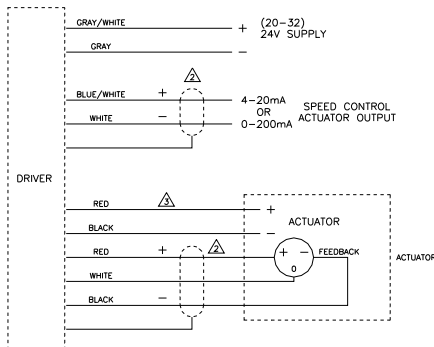

CONDUIT CONNECTOR

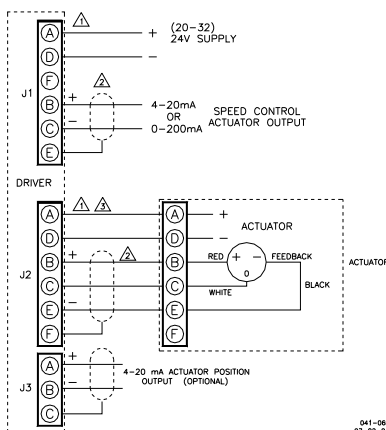

MS TYPE CONNECTOR

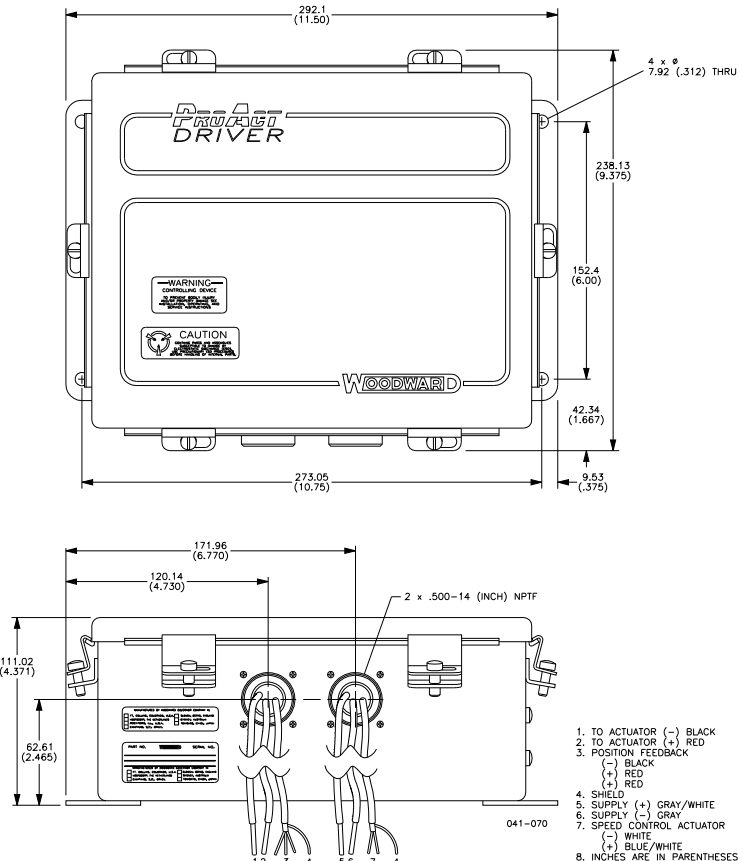

ProAct III and IV Driver Plant Wiring and Outline Drawing (Do not use for construction)

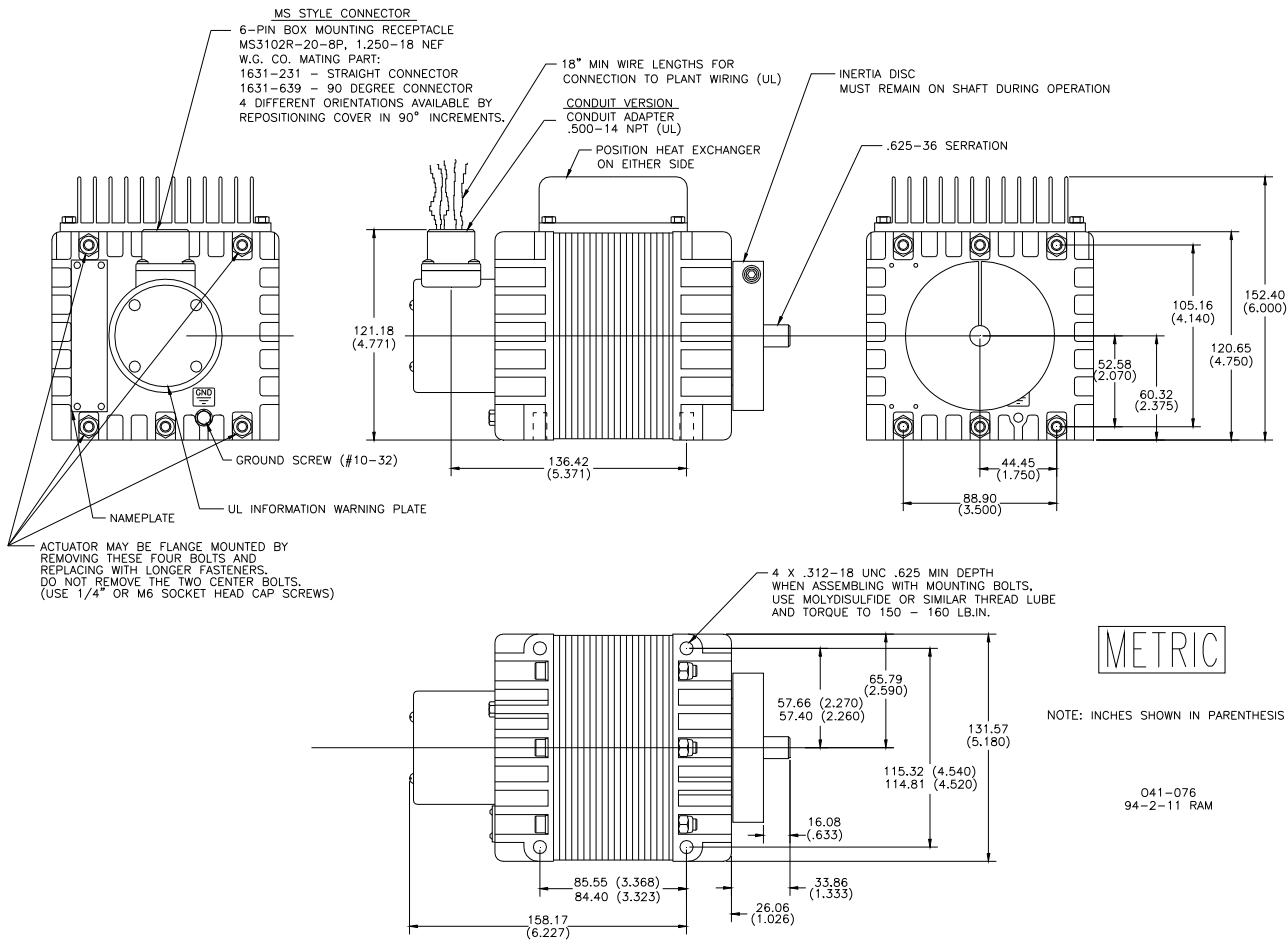

ProAct III Actuator Outline Drawing
 (Do not use for construction)

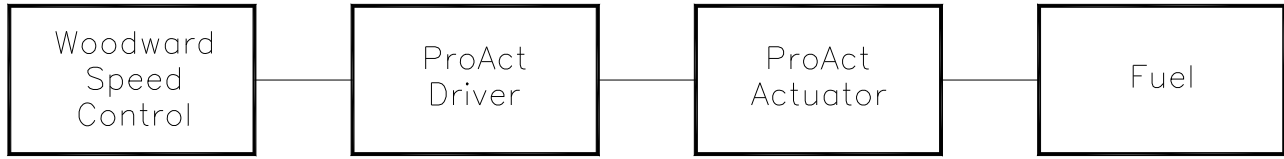

041-138
 94-2-25 RAM

ProAct System Functional Block Diagram

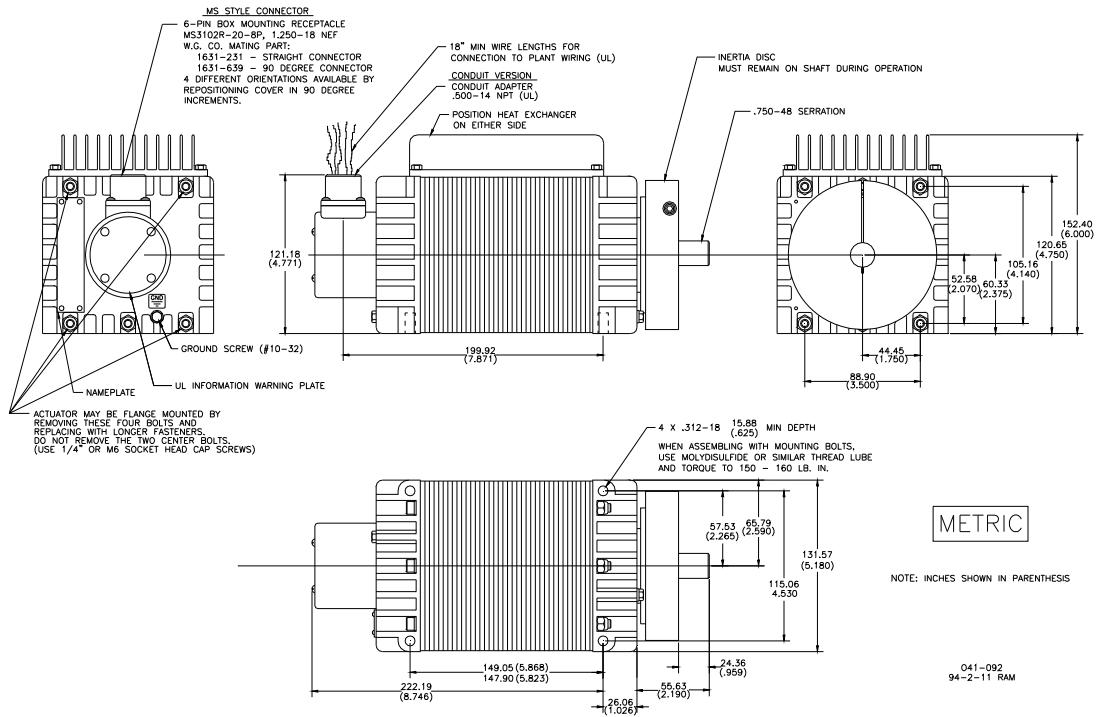

ProAct IV Actuator Outline Drawing
 (Do not use for construction)

Technical Manual 04127



PO Box 1519, Fort Collins CO, USA 80522-1519
 1000 East Drake Road, Fort Collins CO 80525
 Tel.: +1 (970) 482-5811 ♦ Fax: +1 (970) 498-3058
www.woodward.com

Distributors & Service

Woodward has an international network of distributors and service facilities. For your nearest representative, call the Fort Collins plant or see the Worldwide Directory on our website.

This document is distributed for informational purposes only. It is not to be construed as creating or becoming part of any Woodward contractual or warranty obligation unless expressly stated in a written sales contract.

Copyright © Woodward 1994-2007, All Rights Reserved

For more information contact:

