

# UG40 Actuator

## Hydraulic Powered Electric Actuator for Control of Larger Engines

### Applications

The UG40 Actuator is used on diesel, gas, and gasoline engines, (also steam and industrial gas turbines) to replace UG32 or UG40 type governors, providing the advantages of electronic control and load sharing systems with the convenience of the existing UG40 type drive and linkage.

The UG40 Actuator is recommended for installation involving unattended starts.

The UG40 Actuator has its own 7.0-liter (7.4-quart) oil sump and does not need a separate oil supply.

The actuator will operate with a drive speed from 350 to 1300 rpm. A cooler may be needed for applications with a high drive speed and high ambient temperatures.

A magnetic pickup (MPU) may be easily installed in the actuator to make retrofit of engines from mechanical to electronic control easier. A

UG drive in good mechanical condition makes an excellent MPU signal source. Low cranking speeds may require override of the electronic failsafe.

### Description

The UG40 Actuator converts a given electrical input signal to a proportional hydraulic output-shaft position to control engine-fuel flow.

The actuator provides the muscle for Woodward analog controls such as the 2301A, as well as Woodward digital controls.

The standard UG40 Actuator produces 85 N·m (63 lb-ft) of work over 38 degrees of rotary output. Stalled torque is 129 N·m (95 lb-ft). Work output and stalled torque are the same as the UG40 Governor.

The UG40 Actuator uses the same cast-iron case as the UG Governor. The oil pump is the proven high-output Gerotor, designed to provide long life with minimal maintenance. The actuator uses standard UG40 output shafts, power levers, power pistons, and piston links. The base will fit any drive designed for a UG40 Governor. Maintenance procedures are similar to those needed with a UG40 Governor.

The electric-to-hydraulic transducer in the UG40 Actuator uses a Woodward-built torque motor which converts the 20–160 mA control signal to a given output position.



- Proportional electric/hydraulic actuator
- Uses UG40 case and drive for economical installation
- Works with Woodward 20–160 mA output electronic controls
- Self-contained oil supply
- Integral magnetic pickup available

## Specifications

### Work Output

129 N·m (95 lb-ft) stalled torque, 85 N·m (63 lb-ft) of work over 38 degrees

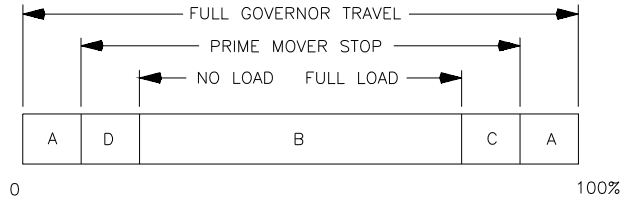
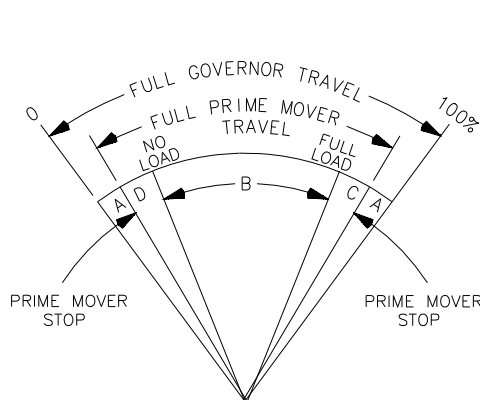

- A - OVERTRAVEL TO INSURE PRIME MOVER STOPS ARE REACHED.  
 B - NO LOAD TO FULL LOAD TRAVEL - NORMALLY 2/3 OF FULL GOVERNOR TRAVEL IS RECOMMENDED.  
 C - TRAVEL REQUIRED TO ACCELERATE THE PRIME MOVER.  
 D - TRAVEL REQUIRED TO DECELERATE OR SHUT DOWN PRIME MOVER.

MI-163a  
98-04-14 skw

MAXIMUM WORK CAPACITY OVER FULL GOVERNOR TRAVEL OF 42° IS \* . SEE ABOVE FOR RECOMMENDED GOVERNOR OUTPUT TRAVEL. IN SPECIAL APPLICATIONS MIN AND MAX PRIME MOVER STOPS MAY BE OUTSIDE THE GOVERNOR STOPS.

### Electrical

Electrical Connector	3 pin, US MIL-STD 3102E-14S-7P, located in cover
Coil Resistance	23–26 Ω at 20 °C
Calibration	1–2 degrees at 20 mA, 32 ±2 degrees additional travel from 20 mA to 160 mA; reaches maximum fuel at less than 200 mA

### Control Qualities

Hysteresis	Within 3% of maximum travel when measured over full 38 degree travel. Within 0.5% of maximum travel when measured over 4% of full travel at 1 Hz.
Temperature Drift	Nominally ±1 degree per 38 °C (100 °F)
Time Constant	150 to 170 ms for ±50 mA step with 1724 kPa (250 psi) actuator oil pressure
Linearity	Within 2.5% of full 38 degree output travel

### Construction

Case, base and power block	are cast iron. Covers are aluminum. Internal parts are case-hardened steel.
Pump	Gerotor: low speed 350–1000 rpm, high speed 600–1300 rpm; relief valve set at 1725 kPa (250 psi)
Output Shaft	(2) 0.750-48 inch serrated; in same location relative to drive as UG40 governor
Drive Shaft	1.125-48 serration is standard; 0.625 keyed drive shaft with 0.625-18 threads available
Weight	29 kg (64 lbs), dry weight
Vibration Resistance	Vibration tested to US MIL-STD 810C, Curve H (10 G to 2000 Hz)

### Drive/Hydraulic Specifications

Drive Speed and Rotation	Actuator available with either high or low speed pump. High speed pump: 600 to 1300 rpm. Low speed pump: 350 to 1000 rpm. Drive operates in one direction only.
Drive Power Requirement	Drive will use a maximum of 525 W (0.7 hp)
Hydraulic Supply	Self contained sump, 7.0 liter (7.4 quart) capacity. See Woodward Manual 25071, <i>Oils for Hydraulic Controls</i> , for specific recommendations. In most cases the same type and weight of oils used in the engine can be used in the governor.
Ambient Temperature Range	–29 to +93 °C (–20 to +200 °F)
Operating Temperature	–29 to +93 °C (–20 to +200 °F) (within the limits of the oil being used in the governor)

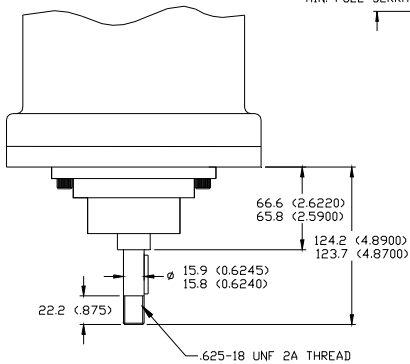
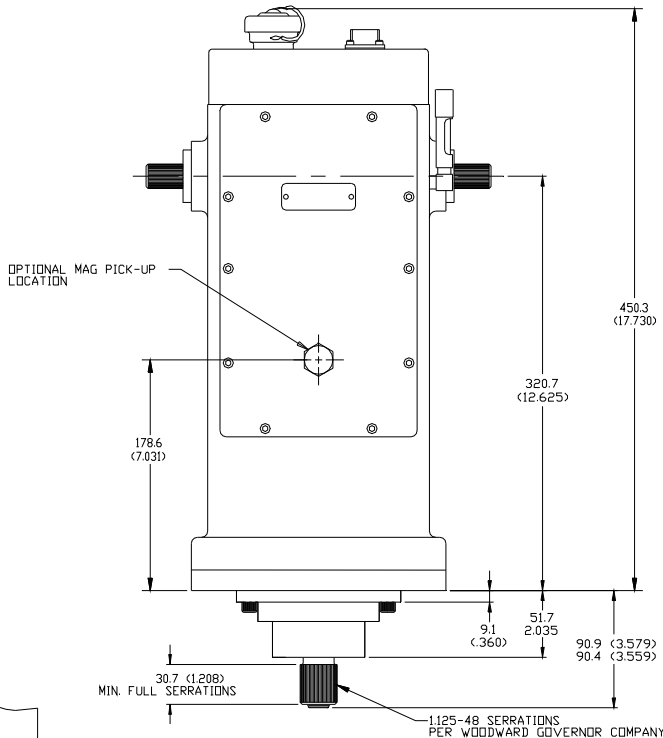
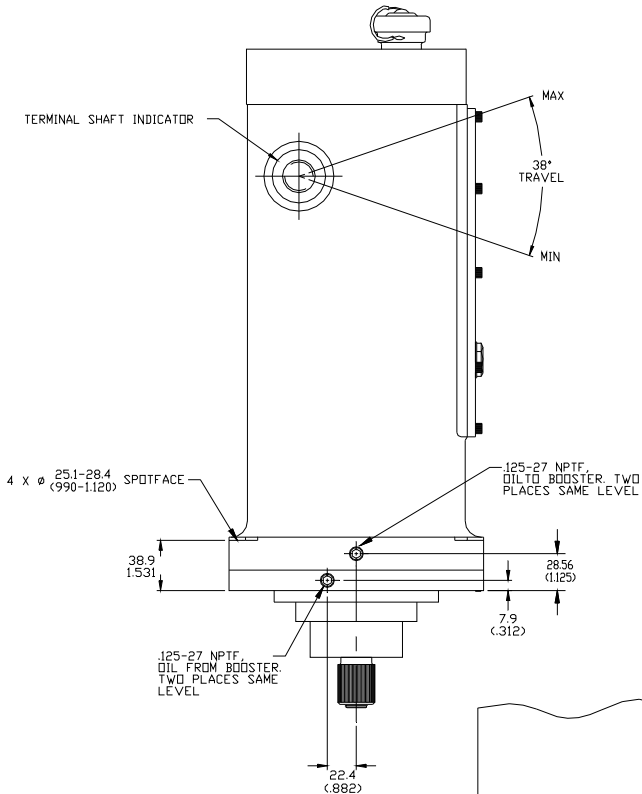
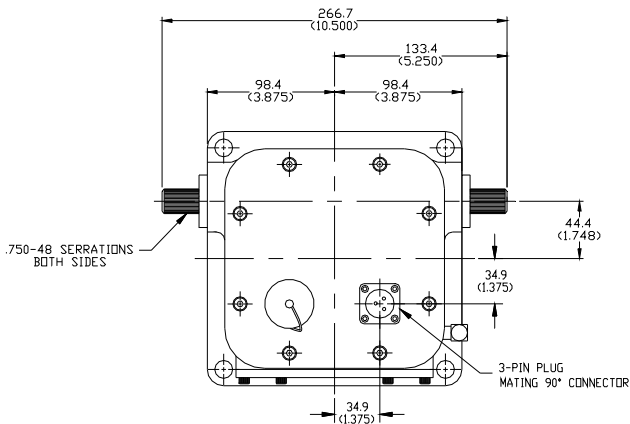
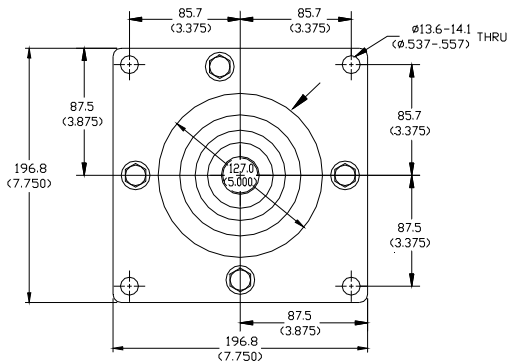

NOTES:  
1. OUTLINE DRAWING OF UG 40 ACTUATOR.  
(TWO TYPES OF SHAFT SHOWN)

METRIC

NOTE: INCHES SHOWN IN PARENTHESIS

375-057a  
98-06-19 skw

KEYED DRIVE SHAFT  
OPTIONAL

**UG40 Actuator Outline Drawing**  
(Do not use for construction)



PO Box 1519, Fort Collins CO, USA 80522-1519  
1000 East Drake Road, Fort Collins CO 80525  
Tel.: +1 (970) 482-5811 ♦ Fax: +1 (970) 498-3058  
[www.woodward.com](http://www.woodward.com)

**Distributors & Service**

Woodward has an international network of distributors and service facilities. For your nearest representative, call the Fort Collins plant or see the Worldwide Directory on our website.

This document is distributed for informational purposes only. It is not to be construed as creating or becoming part of any Woodward contractual or warranty obligation unless expressly stated in a written sales contract.

**Copyright © Woodward 1993–2001, All Rights Reserved**

For more information contact:

