

1907 Large Liquid Fuel Valve

with EM-35 Actuator

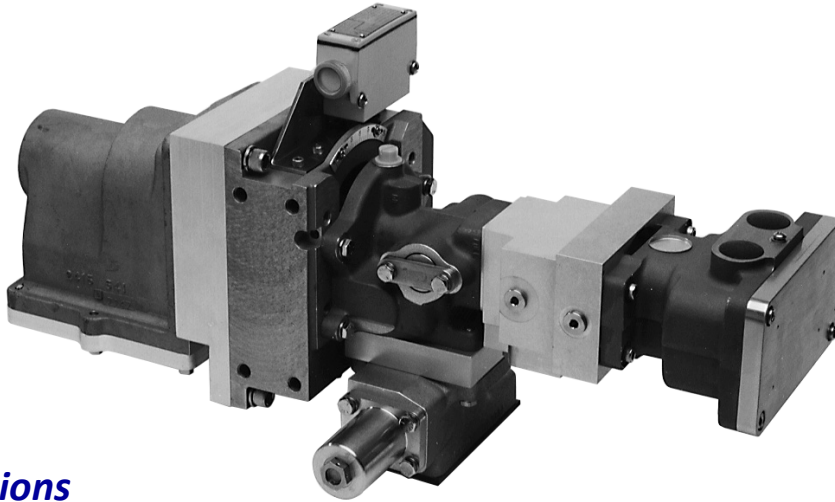

Applications

The 1907 large liquid fuel valve accurately meters liquid fuel to a gas turbine during acceleration, steady-state operation, and deceleration. The valve may be used for almost any liquid-fueled industrial gas turbine application within its range of fuel flow 68 to 11 340 kg/h (150 to 25,000 lb/h). When used in conjunction with an EM-35 actuator and EM-35 digital driver, the 1907 valve delivers the demanding accuracy needed for DLE applications.

The EM-35 actuator is all electric, so hydraulic contamination and maintenance problems are eliminated. Cost is reduced since there is no HPU to maintain or replace. In addition, the EM-35 actuator is designed for long life, although it may be replaced in the field if necessary. The EM-35 actuator is designed for use with both analog and digital EM-35 motor drivers. The motor is a brushless dc motor with a motor clutch and gearhead assembly. The motor uses Samarium Cobalt permanent magnets bonded and sleeved to the rotor element. Rotor position sensing is performed through the use of a brushless field director, and motor velocity feed is performed by means of a brushless tachometer.

Features

The EM-35 motor assembly is housed in a cast aluminum explosion-proof housing. A thermal potting compound is used to transfer heat generated by the motor to the cast housing and out to the ambient environment.

EM-35 Analog Driver

The analog driver contains an analog position controller that receives a demand signal via a 4–20 mA input. The feedback signal is generated by a brushless resolver that is mounted on the fuel metering valve. The driver contains fault detection circuitry which provides the status of the 4–20 mA interface, position controller, driver, and feedback to the shutdown logic. A fault condition or an external shutdown command will disable the output (removing power from the motor), which in turn causes the valve return spring to close the valve. An analog velocity controller is used to reduce the effect of friction in the valve.

- Accurately meters flow from 68 to 11 340 kg/h (150 to 25,000 lb/h)
- Handles most liquid fuels
- Accommodates different fuel and schedule requirements
- Needs no on-site adjustments
- All electric
- Low maintenance
- Designed for long life
- Models are available with certification for North American Hazardous Locations
- Choice of operating modes

1907 Large Liquid Fuel Valve Specifications

SUPPLY CHARACTERISTICS

Fuel Type	The valve is compatible with most types of diesels, kerosenes, gasolines, heavy and light distillates including naphtha, gas turbine fuels and fuel oils, and other liquid fuels such as biodiesel that are compatible with fluorocarbon (FKM) type elastomers and conform to international standards for utility, marine, and aviation gas turbine service. Ultra low sulfur diesels are also acceptable with proper lubricity additives. Other fuels such as ethanol or methanol may be acceptable with internal seal compound substitutions. Contact Woodward for these and other special fuel applications.
Fuel Viscosity	Fuel viscosity must be between 0.5 and 12.0 centistokes.
Fuel Cleanliness	Liquid fuel must be filtered to limit particulate size to 20 µm or smaller. Water content must be limited to 0.1% by volume. Solids, sediment, and particulates must be limited to 1.0 mg per liter of fuel.
Fuel Specific Gravity	0.77 to 0.91
Fuel Schedule (Nominal)	
Minimum Flow	68 kg/h (150 lb/h)
Maximum Flow	11 340 kg/h (25,000 lb/h)
Maximum Bypass Flow	13 608 kg/h (30,000 lb/h)
FUEL PRESSURE	
Inlet maximum operating pressure	9377 kPa (1360 psig) with aluminum body 17 238 kPa (2500 psig) with stainless steel body using grade 8 bolts and o-ring style gasket on mounting flange
Outlet maximum operating pressure	9032 kPa (1310 psig) with aluminum body 16 893 kPa (2450 psig) with stainless steel body using grade 8 bolts and o-ring style gasket on mounting flange
Differential Pressure	345 to 827 kPa (50 to 120 psig)
PORTING	
Overboard Drain	MS33649-4
Inlet and Bypass	MS33786
Outlet	MS16142 (-20) (except minor diameter to accept "J" threads)
Flow Range	30 to 1
Valve Travel	60°

General Specifications

Operating Temperature	-18 to +121 °C (0 to 250 °F)
Mounting Configuration	any configuration
Construction Material	stainless steel or aluminum (1907 valve)

WEIGHT

Aluminum	3.1 kg (6.8 lb)
Stainless Steel	8.5 kg (18.8 lb)

EM-35 Actuator Specifications

MECHANICAL	
Output Shaft Rotation	60° (rotation limited by valve stops)
Continuous Output Torque	25 N·m (+220 lb-in) maximum
Peak Output Torque	45 N·m (+400 lb-in) minimum

ELECTRICAL

Power Input	24 Vdc nominal 18–32 Vdc operating
Current	25 A, maximum for 100 ms 15 A, maximum continuous 3 A, expected steady state

PERFORMANCE

Slew Rate	>400°/sec (24 Vdc @ motor)
Bandwidth	>4.5 Hz
Position Accuracy	0.50° analog 0.10° digital

EM-35 Digital Driver

This driver, designed for use with a Woodward NetCon[®] control system, consists of a position controller module and a remote driver. The position controller module and the digital driver exchange information over serial communication lines. The digital form of the data preserves the 16-bit feedback resolution necessary to meet the system accuracy requirements. The position controller module is configured during the system initialization with data selected off-line by the Menu Oriented Editor (MOE[™]) or the Graphical Application Program (GAP[™]) software. Controller, driver, and feedback status is provided by the IACT_EM software block.

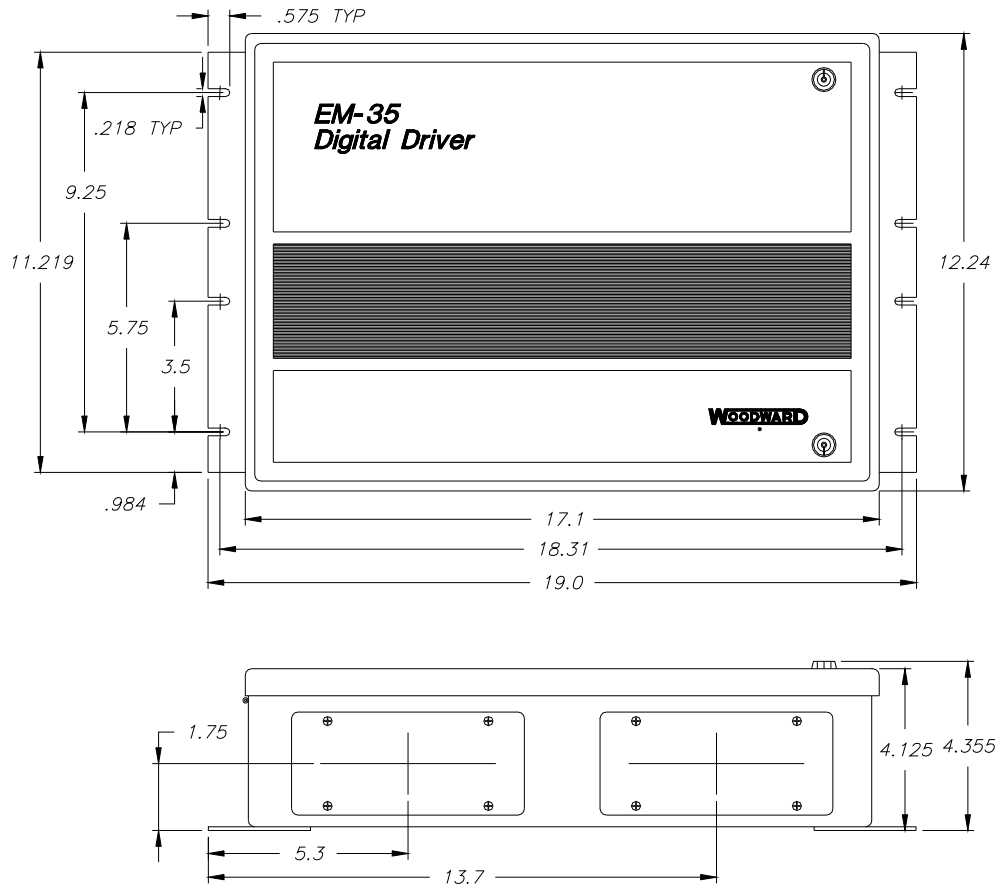

824-783
95-09-26 KDW

Outline Drawing of EM-35 Digital Driver
(Analog driver dimensions are identical.)
(Do not use for construction)



PO Box 1519, Fort Collins CO, USA 80522-1519
1000 East Drake Road, Fort Collins CO 80525
Tel.: +1 (970) 482-5811 • Fax: +1 (970) 498-3058
www.woodward.com

Distributors & Service

Woodward has an international network of distributors and service facilities. For your nearest representative, call the Fort Collins plant or see the Worldwide Directory on our website.

This document is distributed for informational purposes only. It is not to be construed as creating or becoming part of any Woodward contractual or warranty obligation unless expressly stated in a written sales contract.

Copyright © Woodward 1994–2006, All Rights Reserved

For more information contact:

